

Paneling

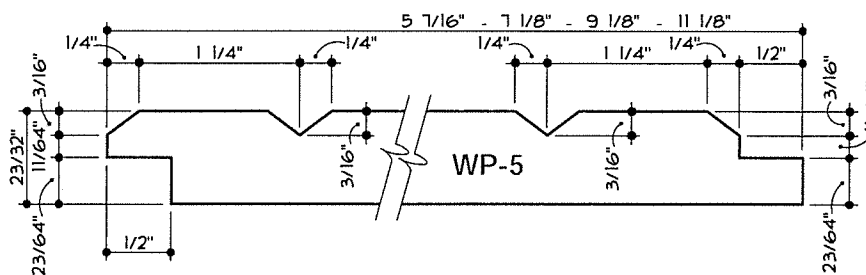

Paneling

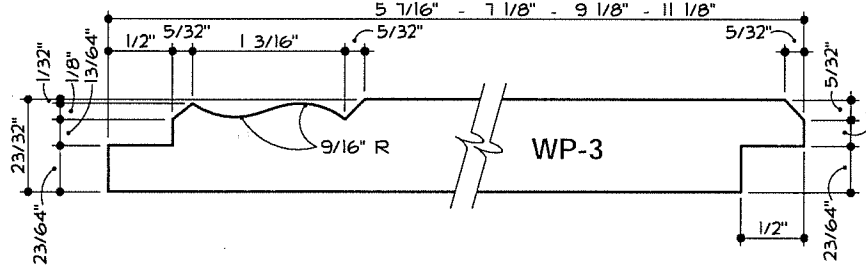
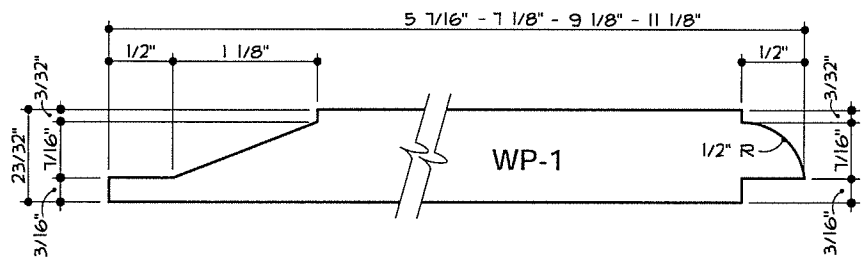
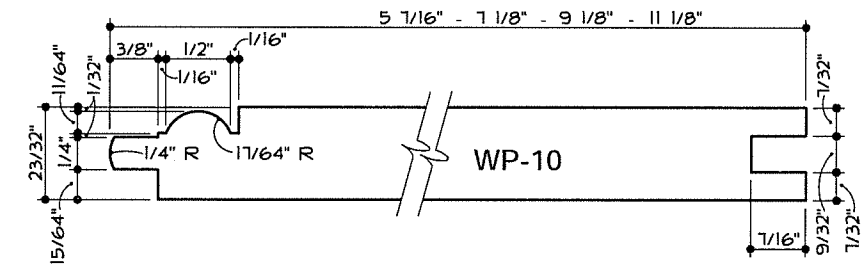
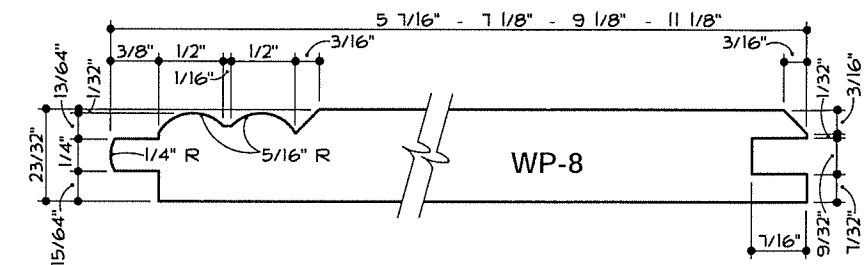
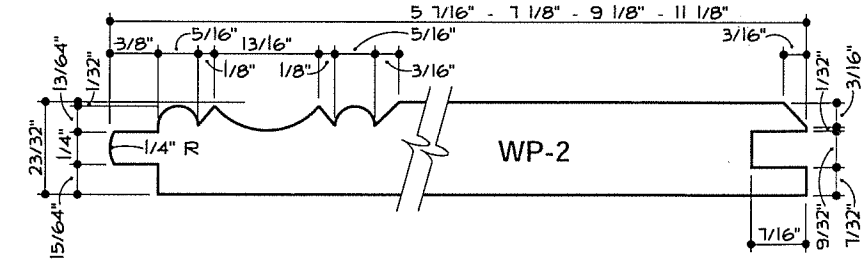
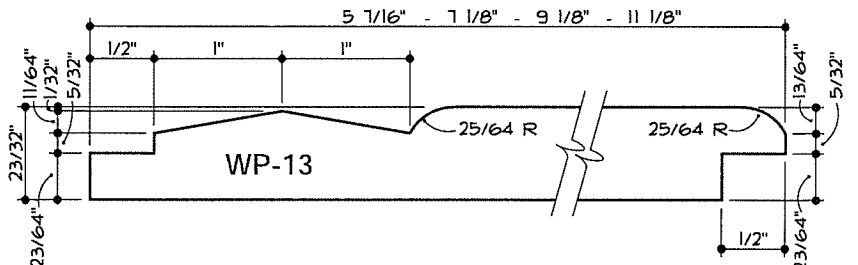
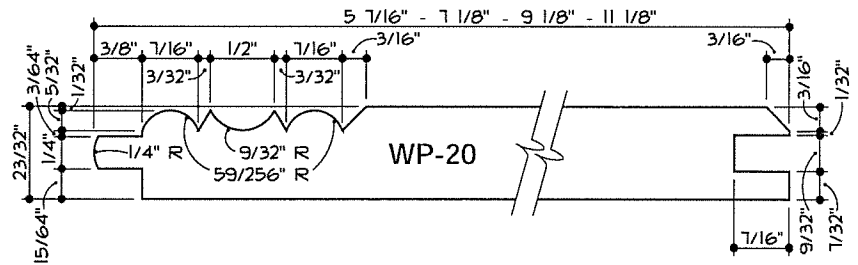
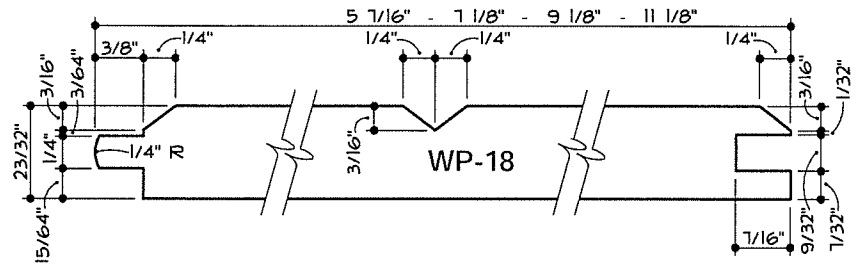
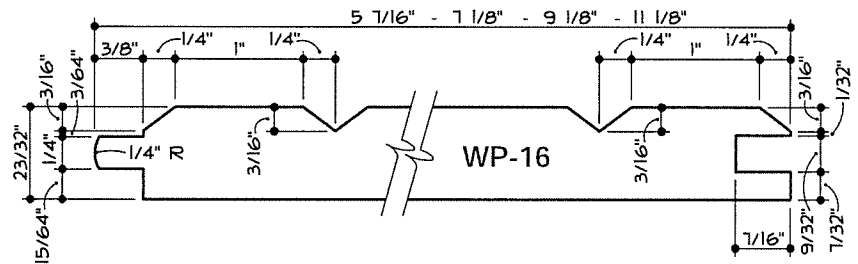
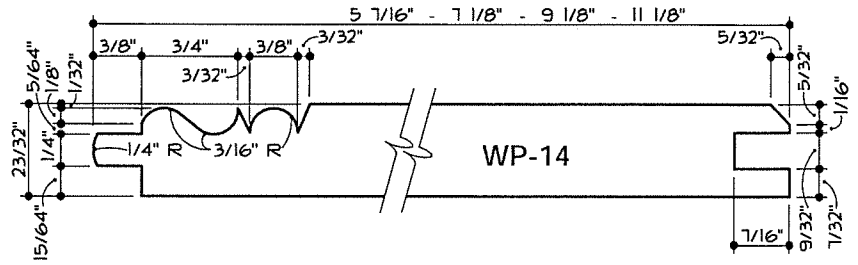
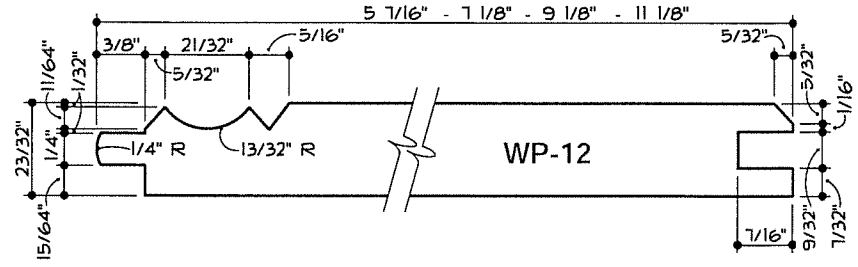

Paneling and Siding

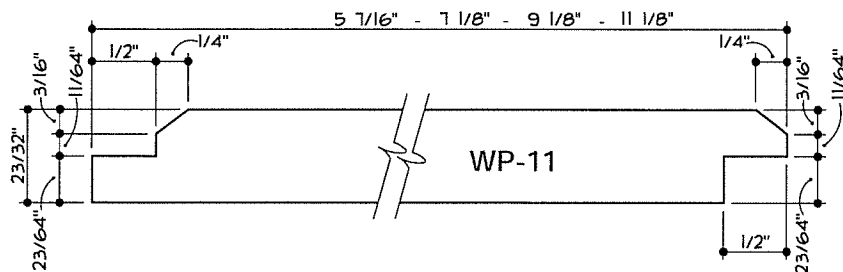
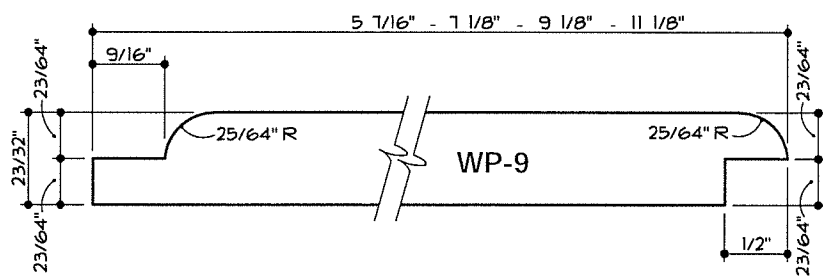
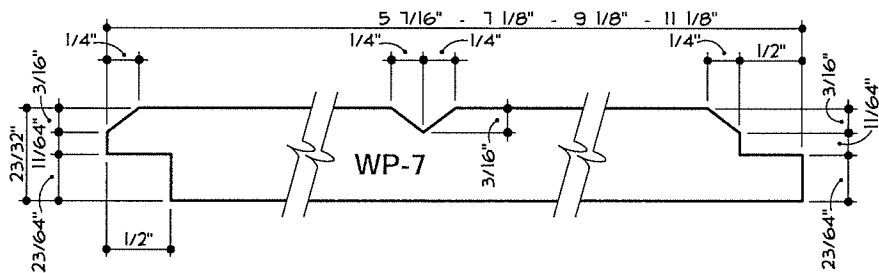
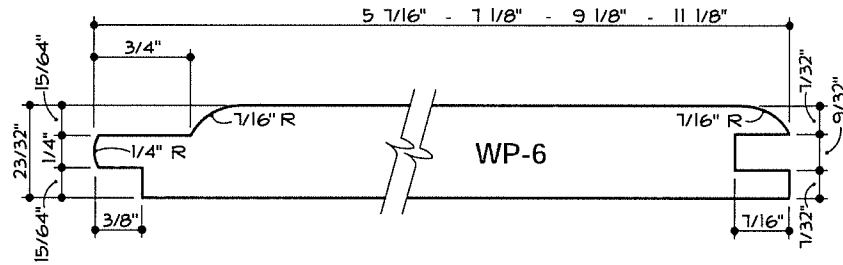
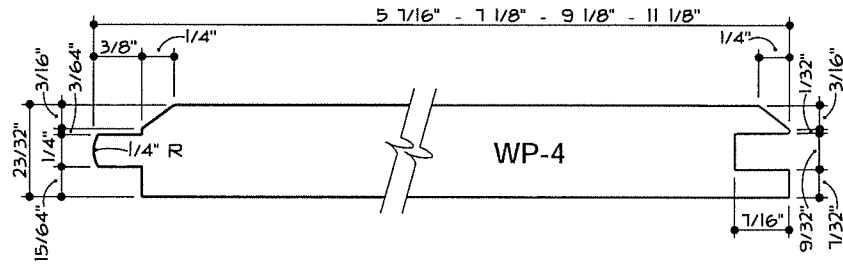
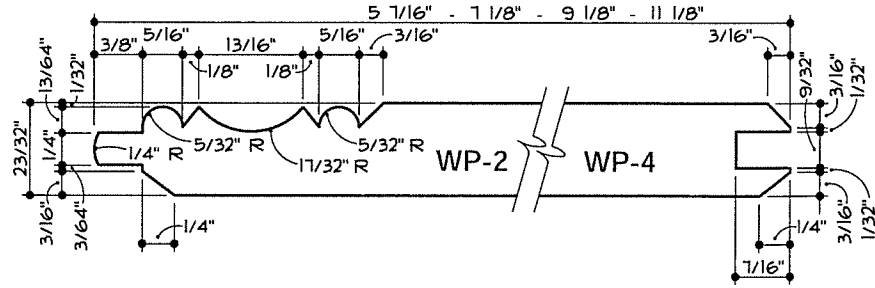

Siding

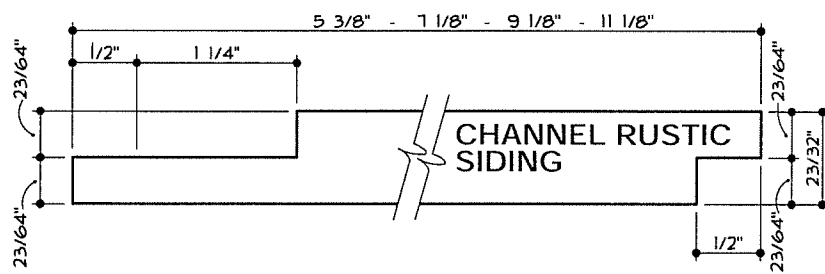
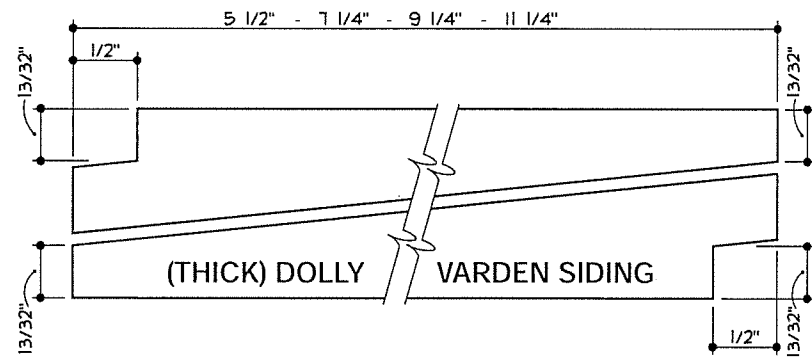
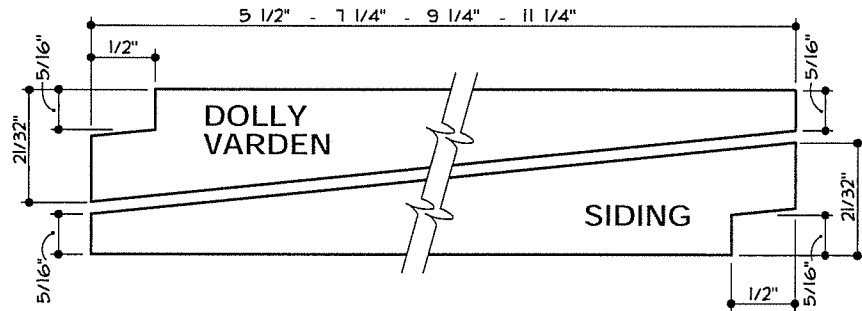
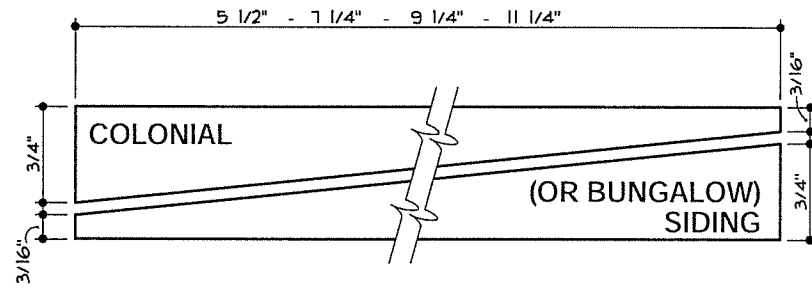
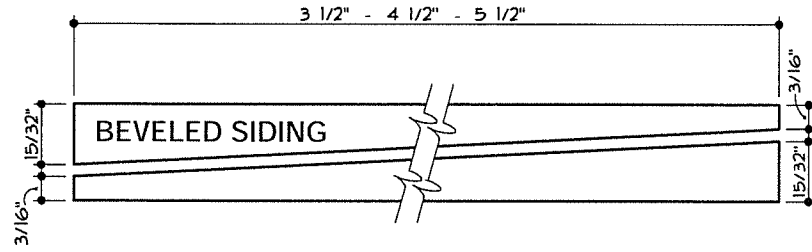

Siding

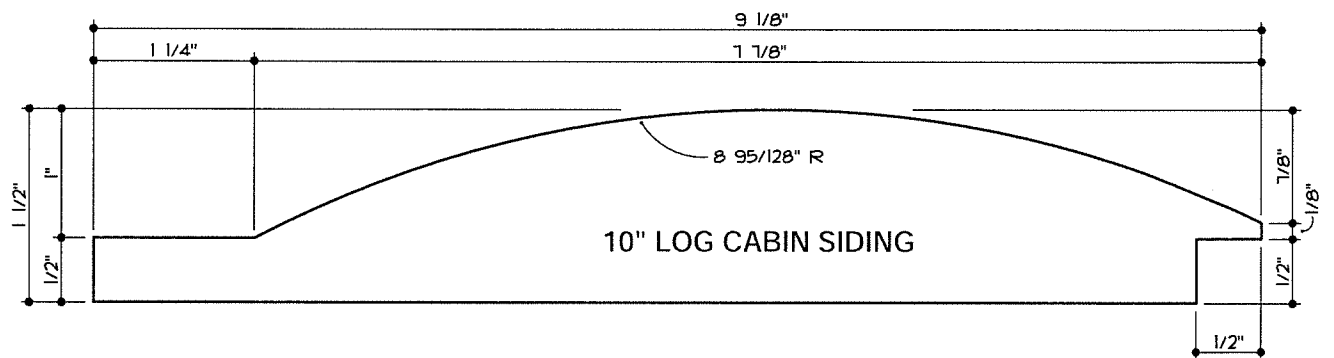
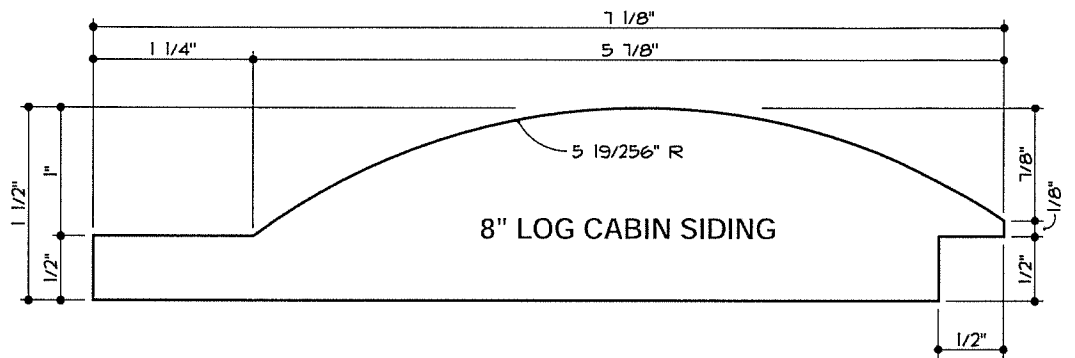
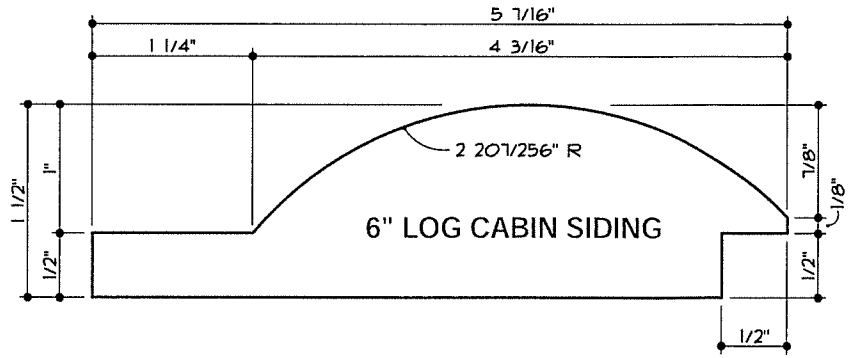

Siding

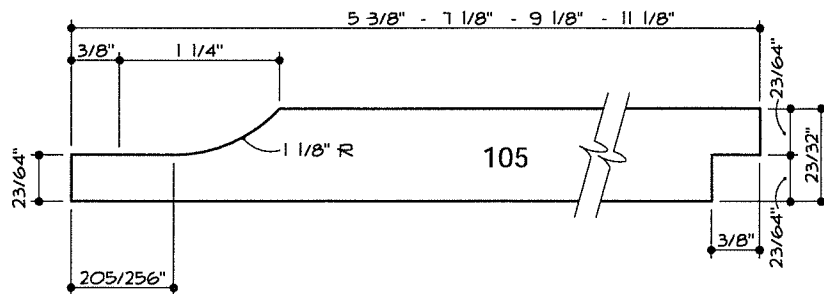
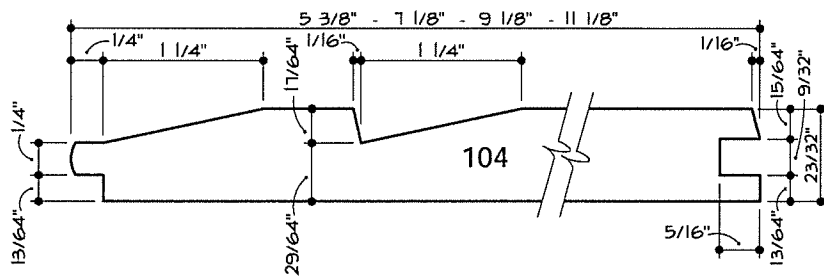
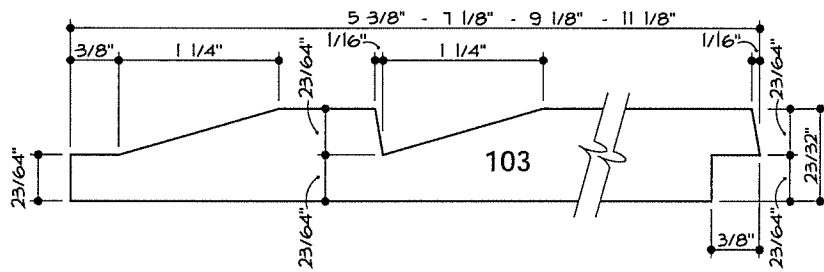
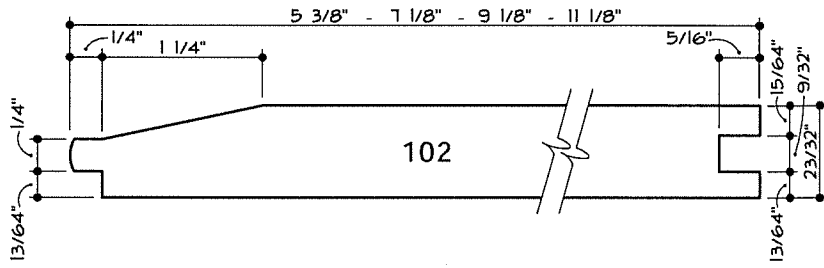
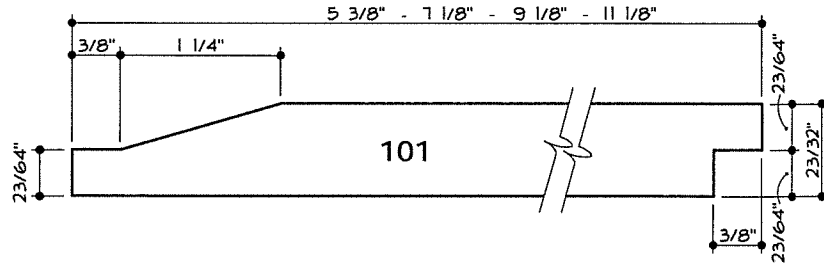

Siding

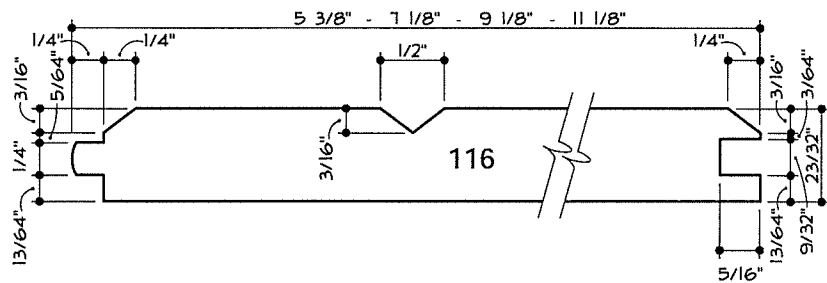
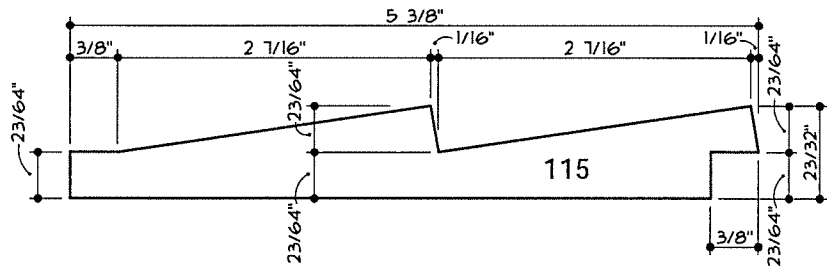
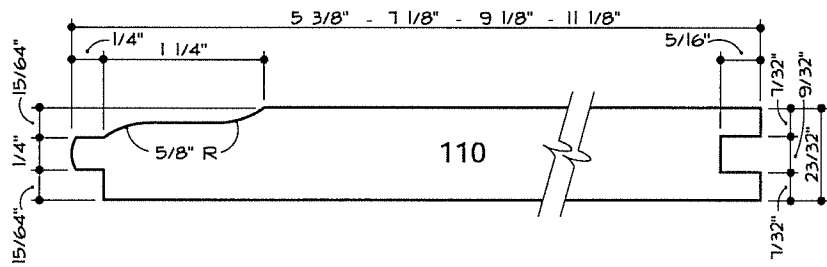
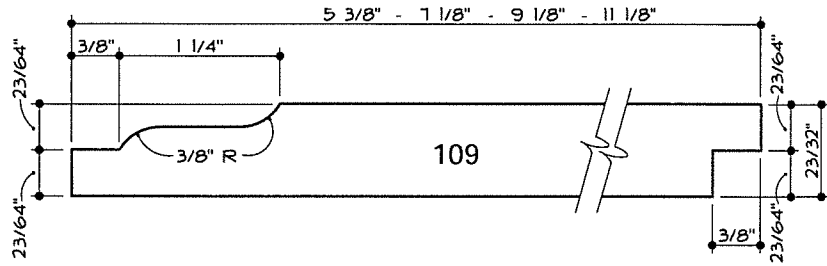
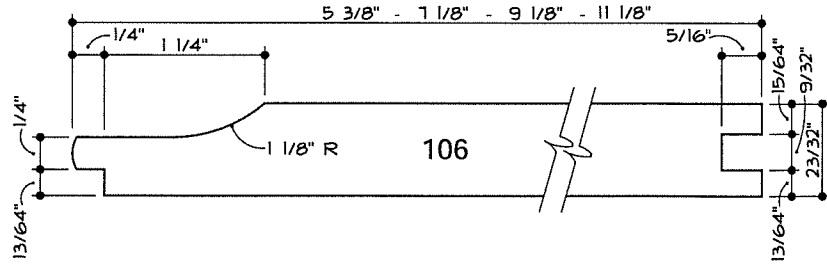

Siding

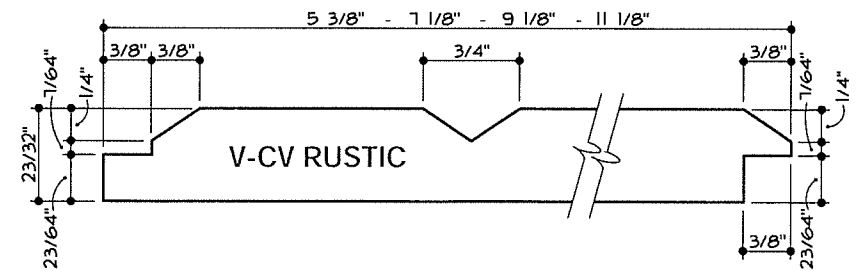
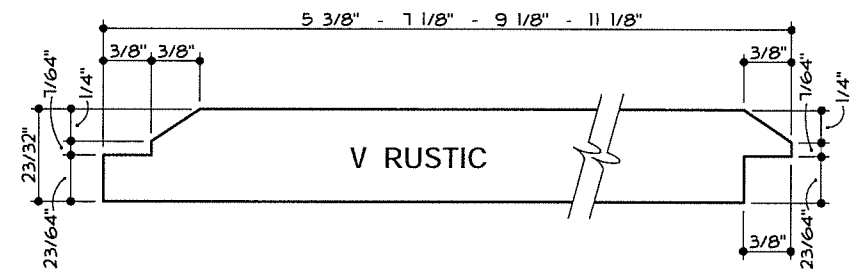
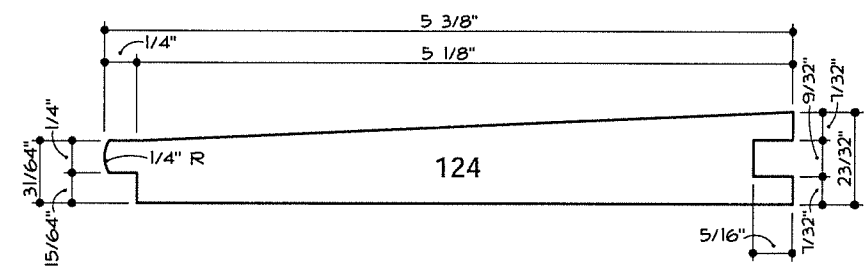
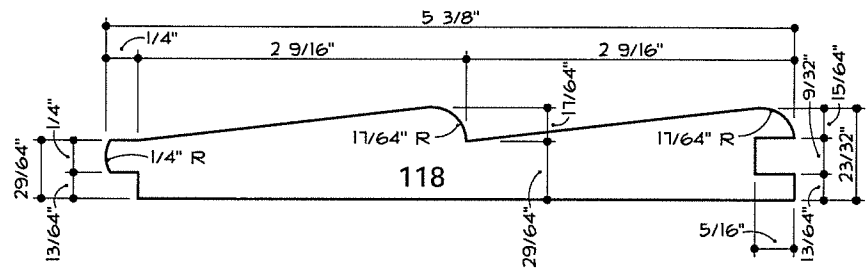
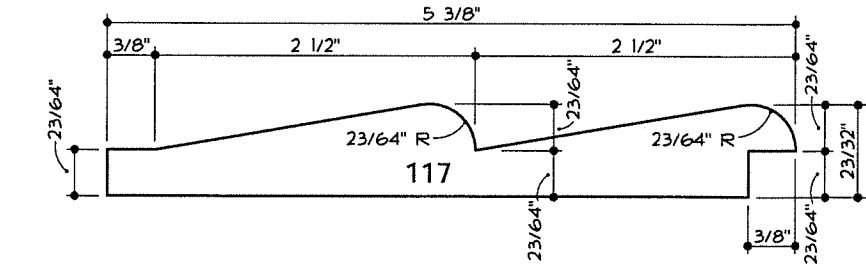

Ceiling

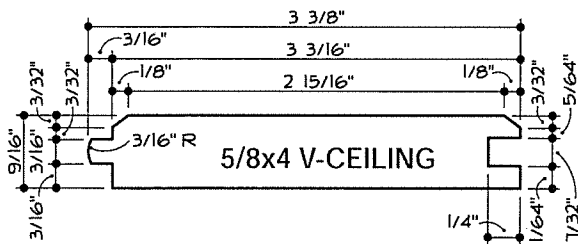
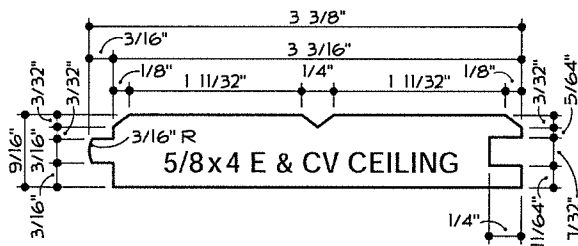
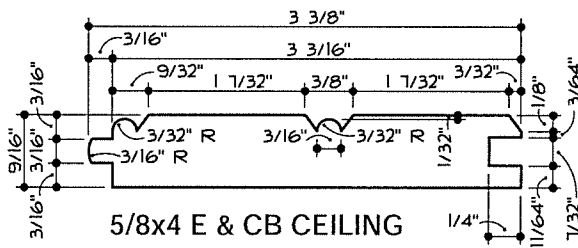
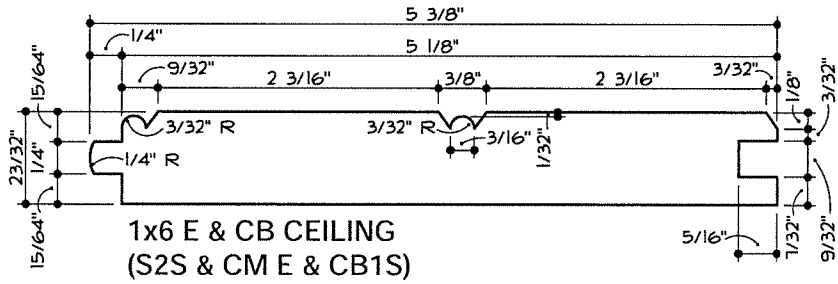
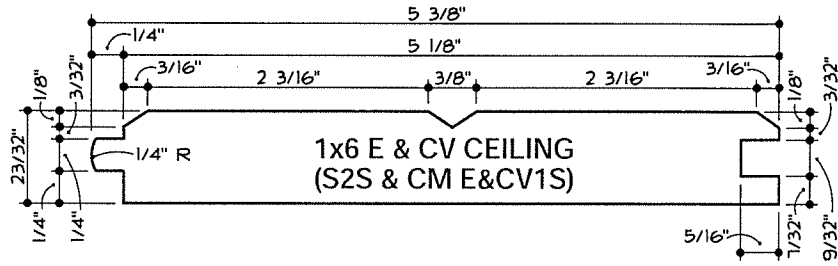
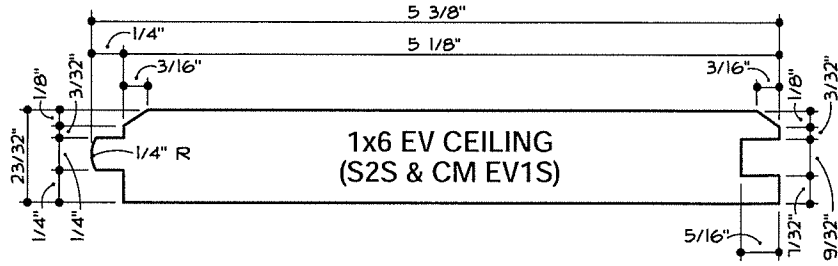

Ceiling and Partition

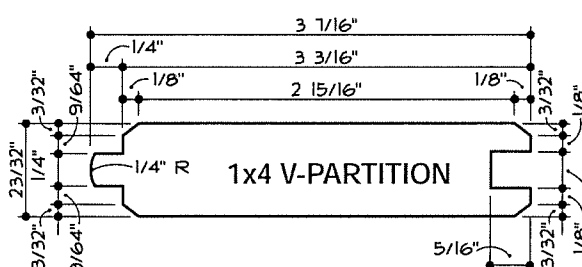
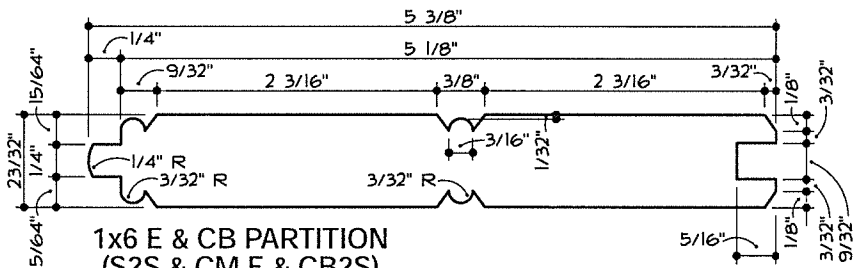
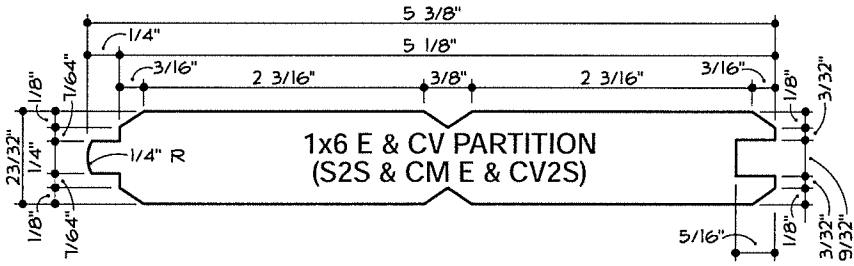
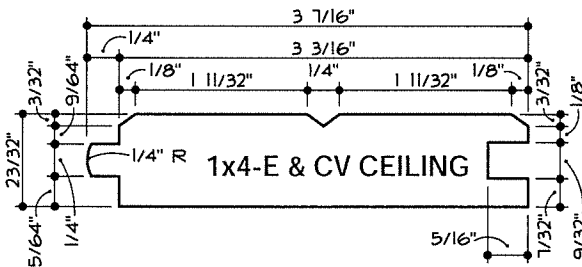
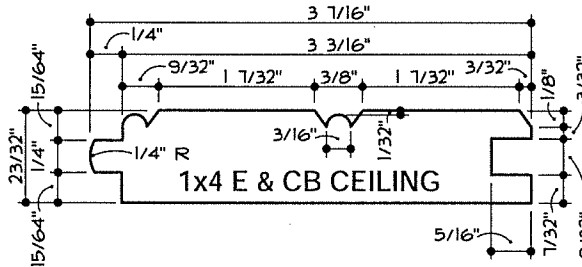
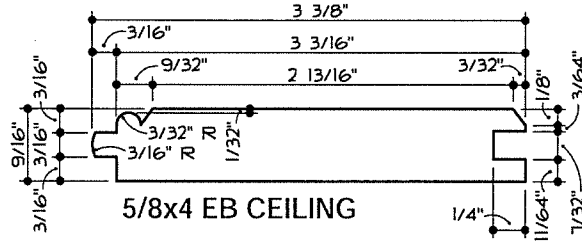

Partition

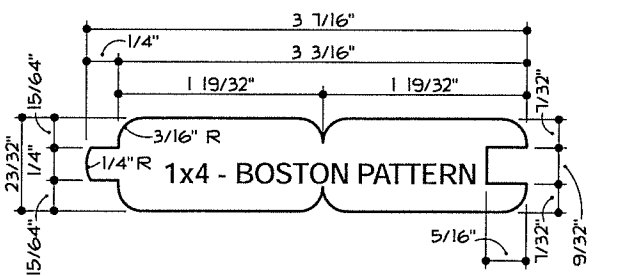
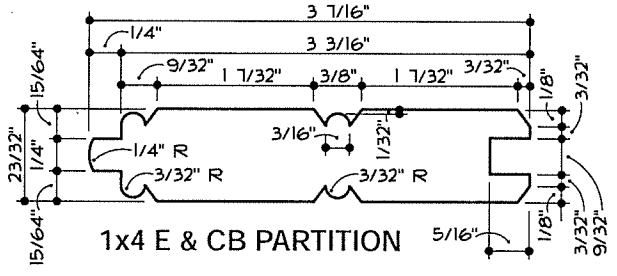
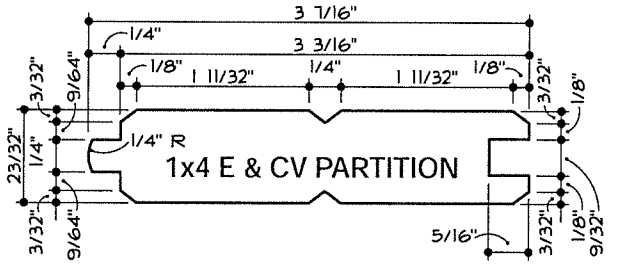
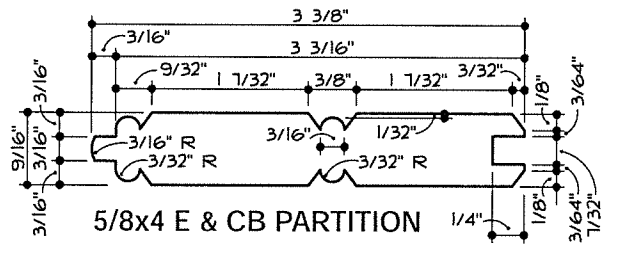
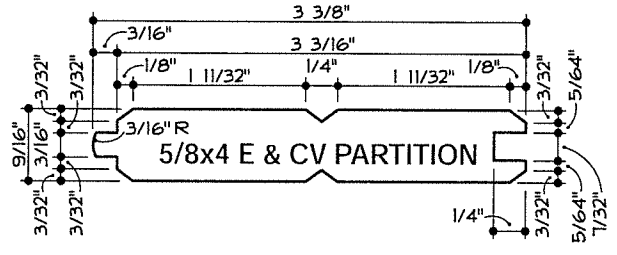
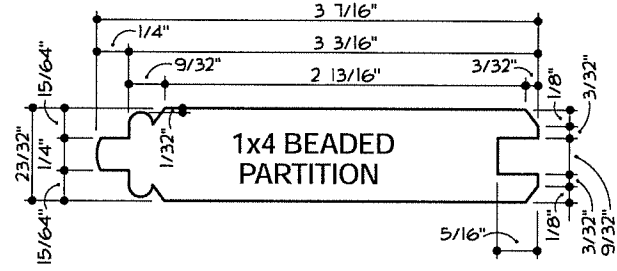

Shiplap

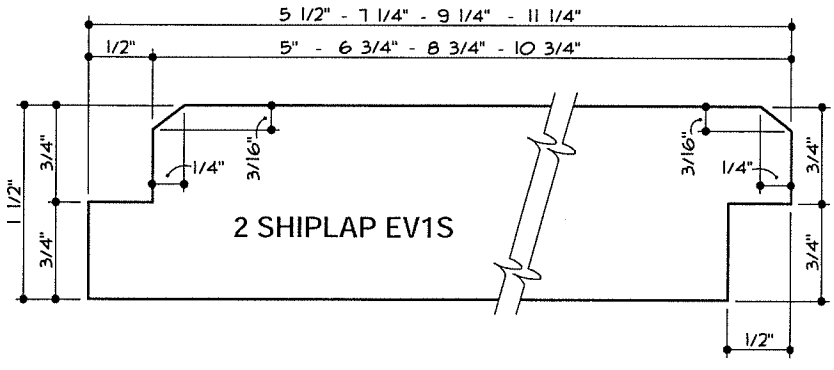
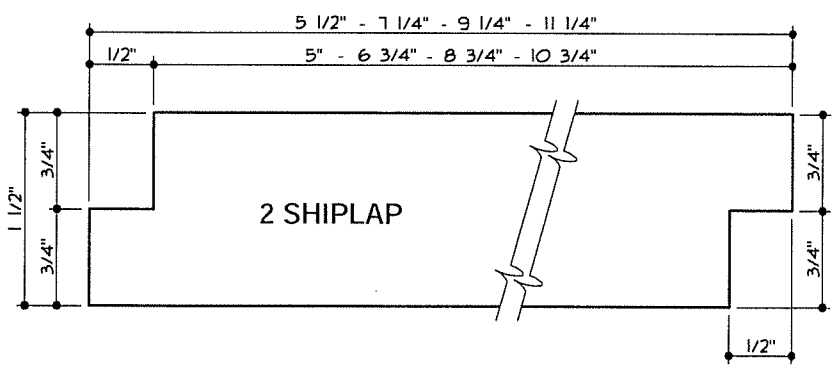
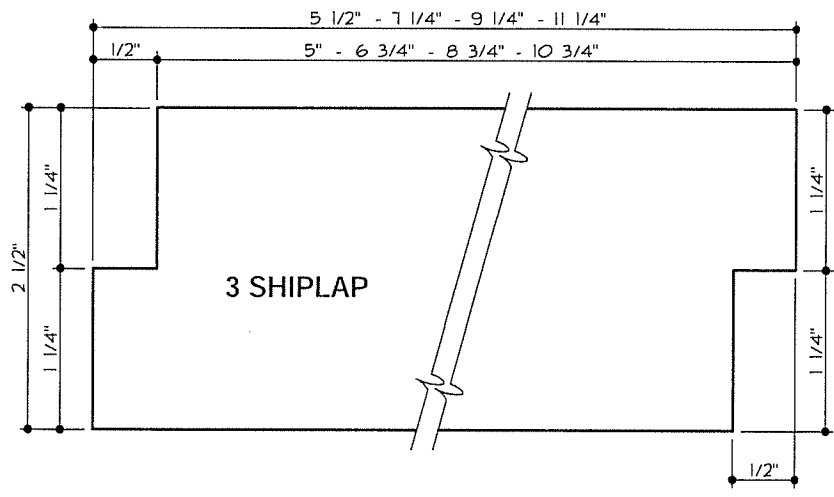
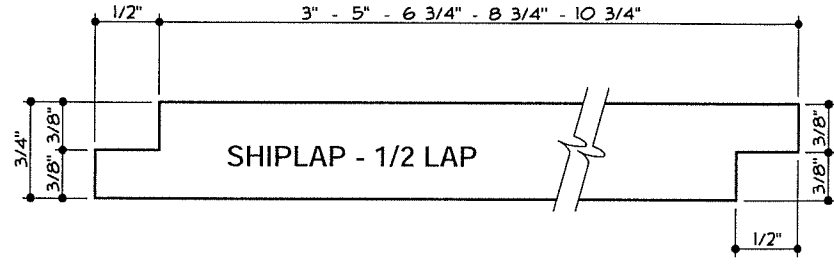
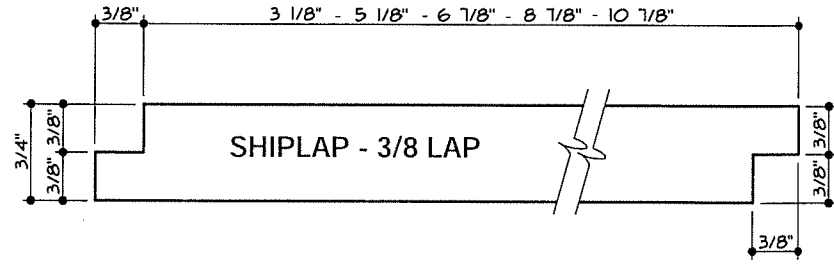

Tongued & Grooved, Decking

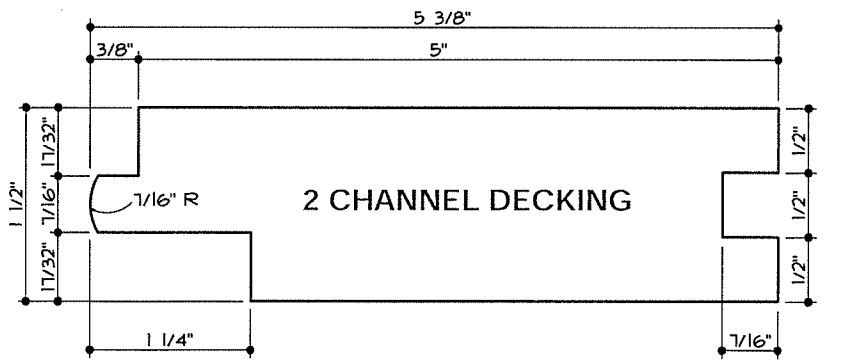
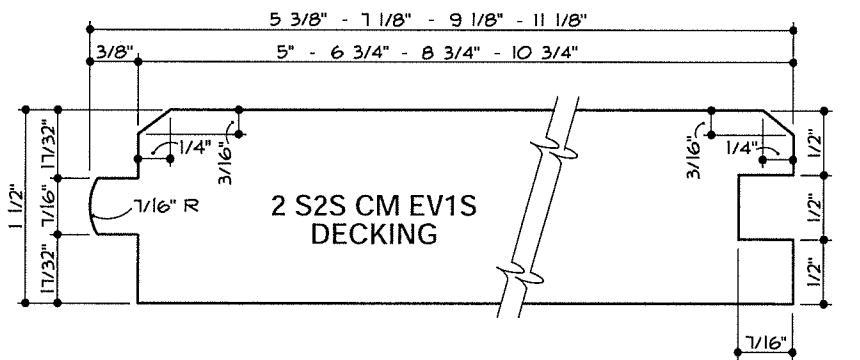
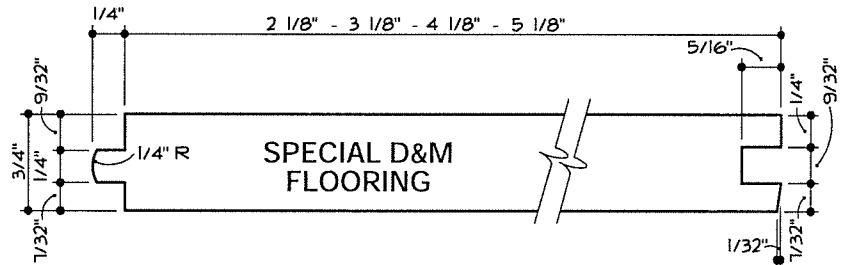
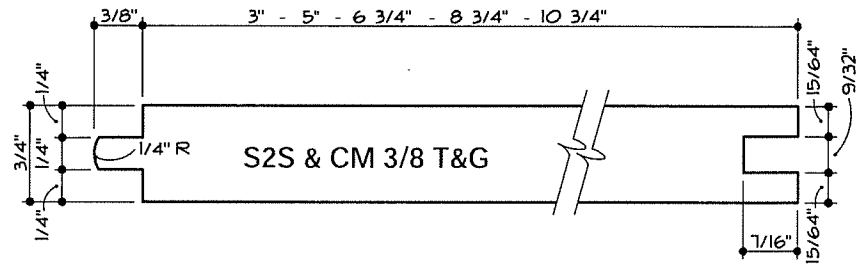
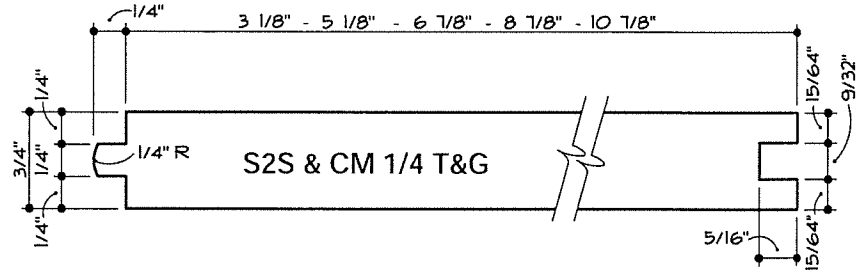

Decking

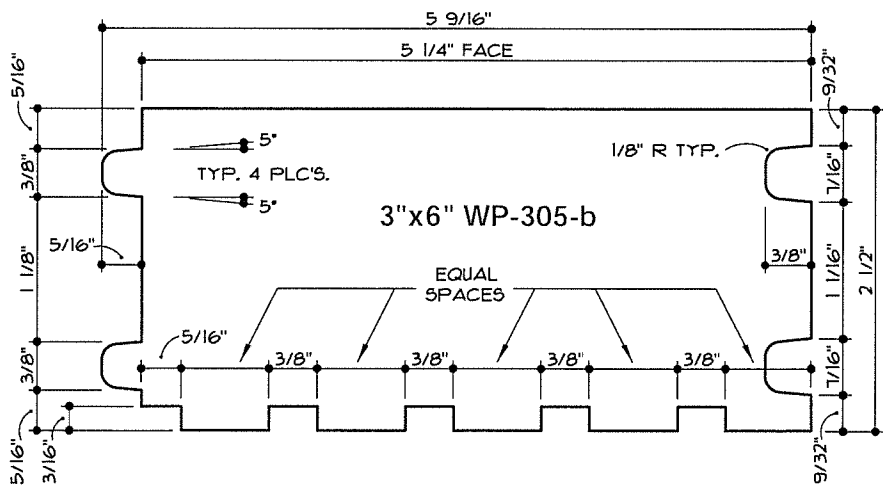
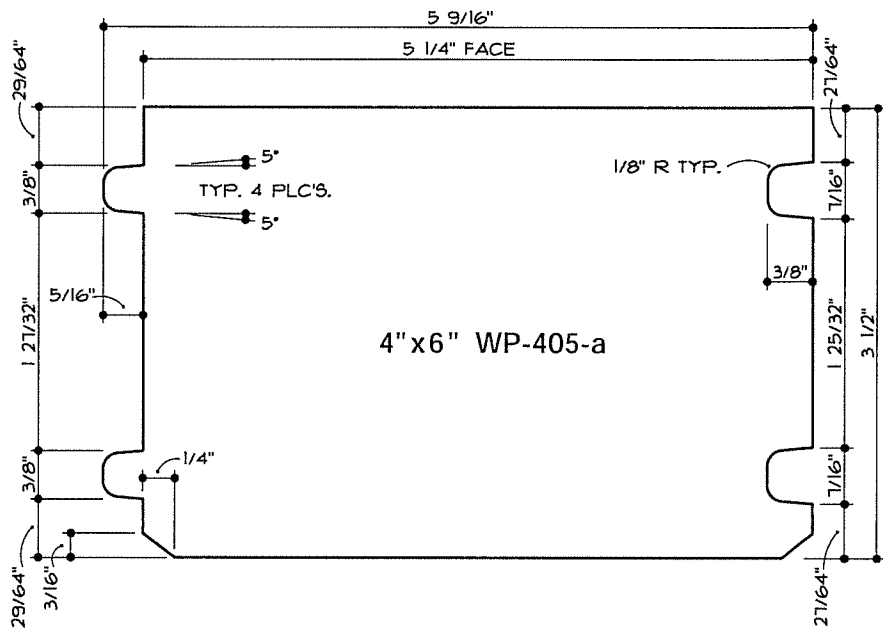
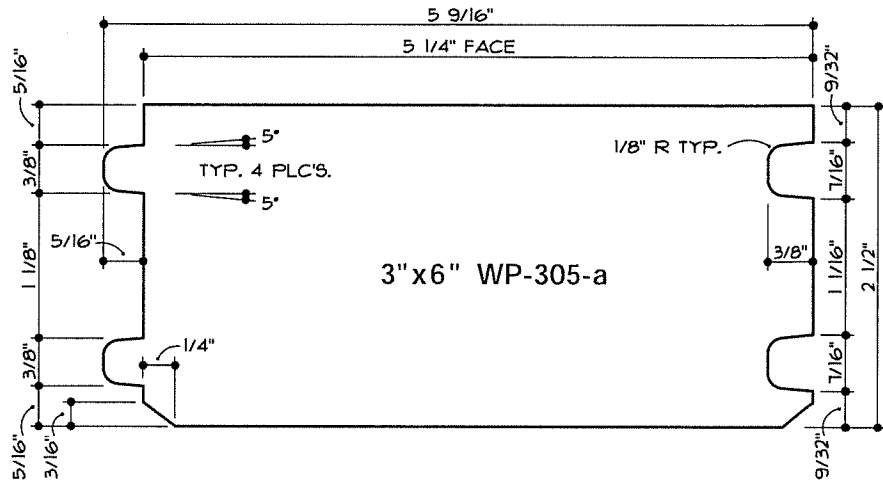

Decking

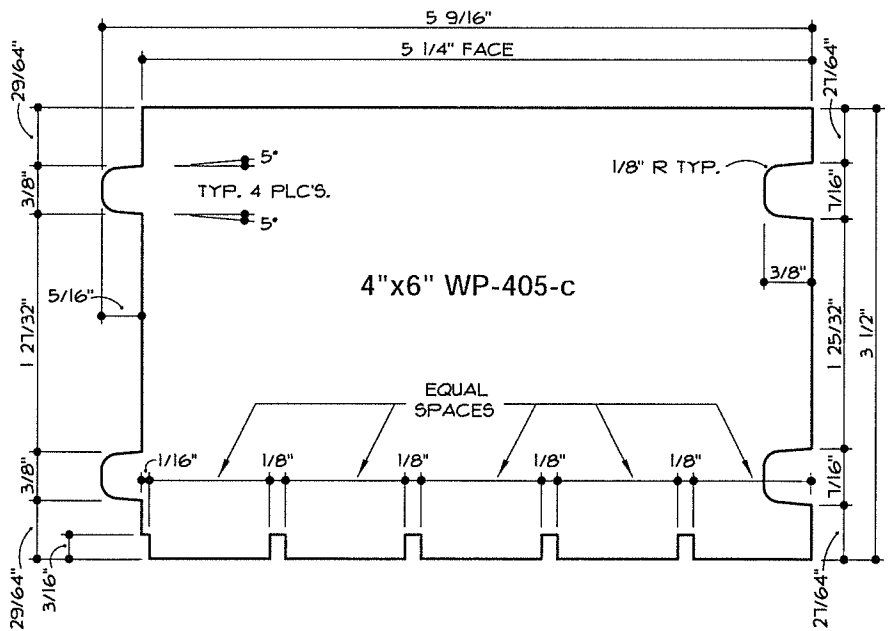
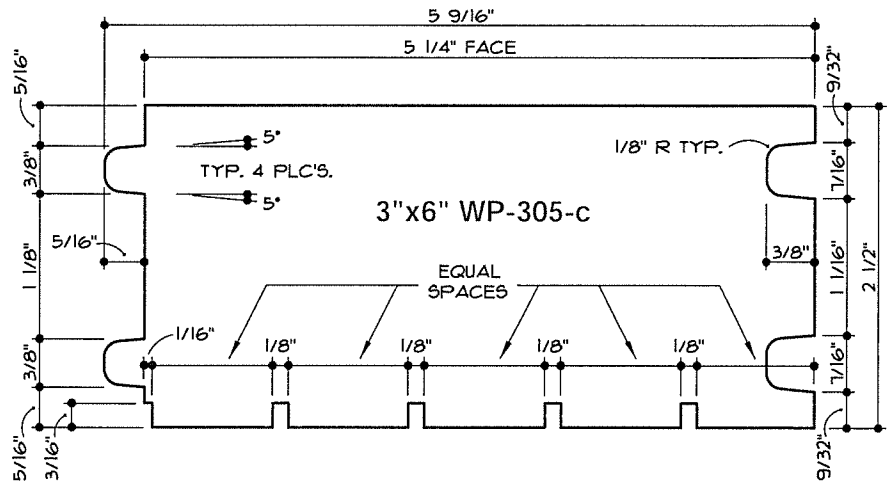
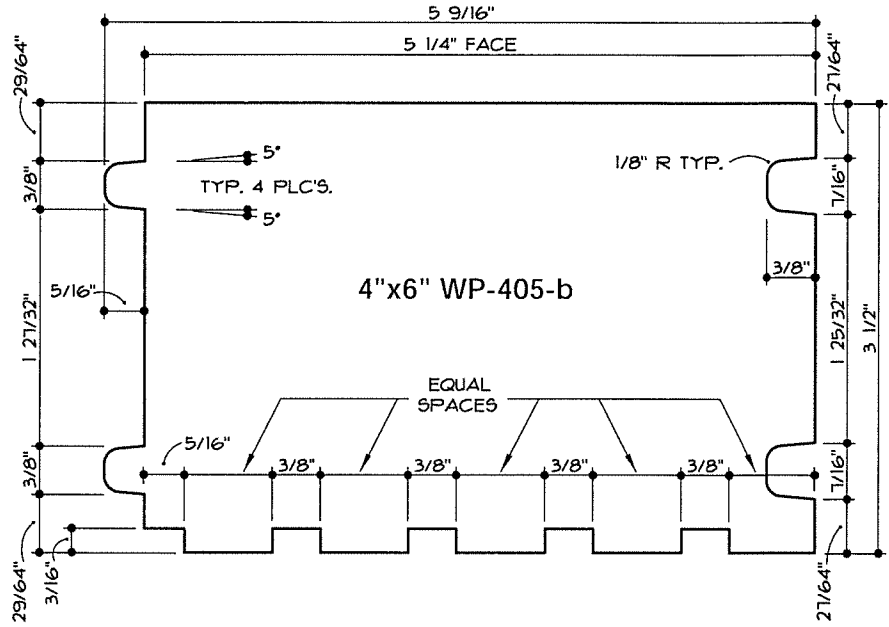

Decking

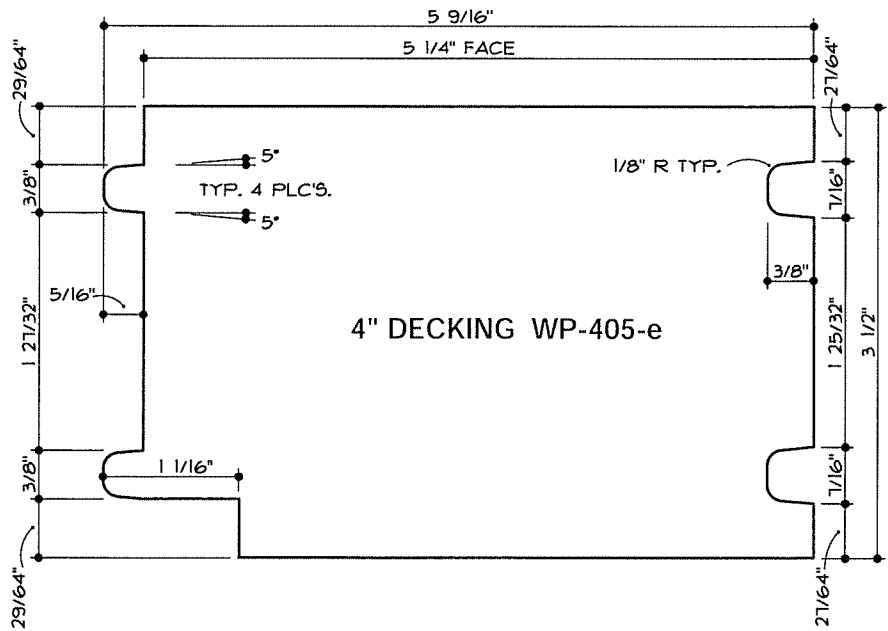
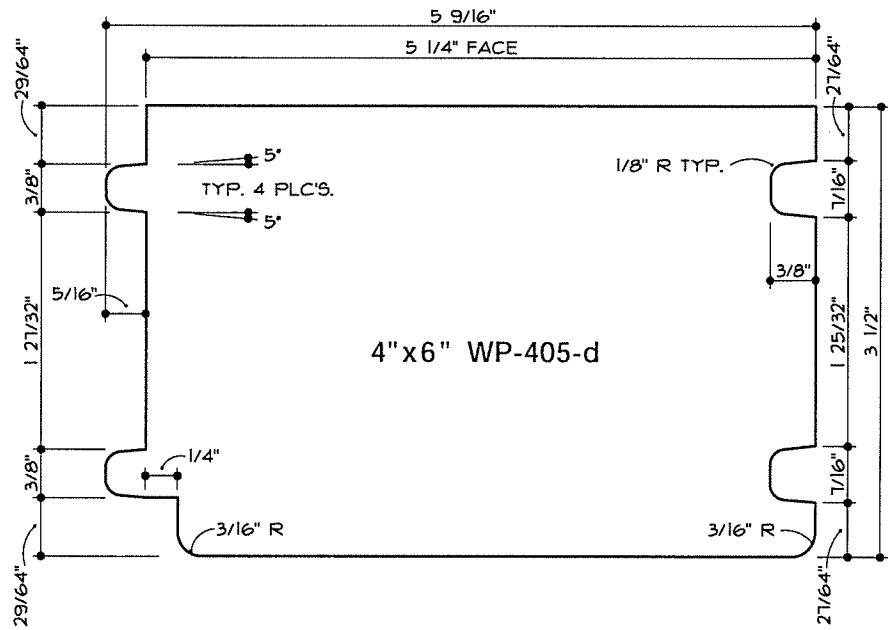
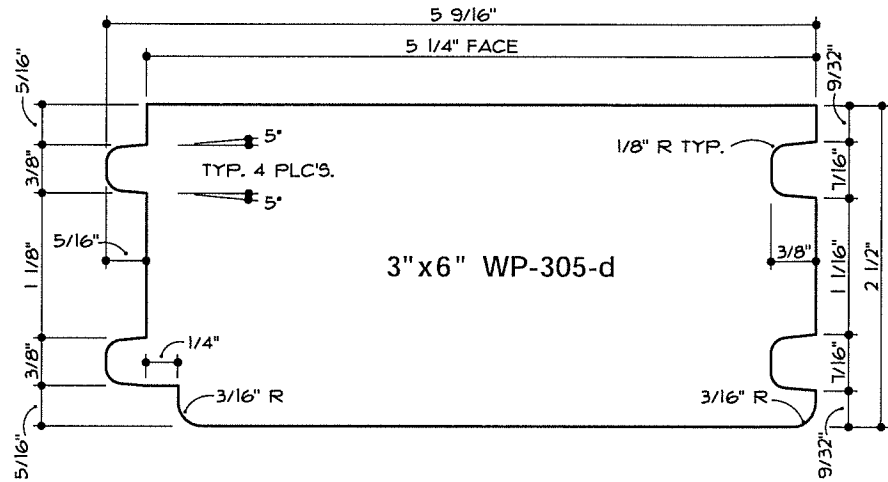

Decking and Flooring

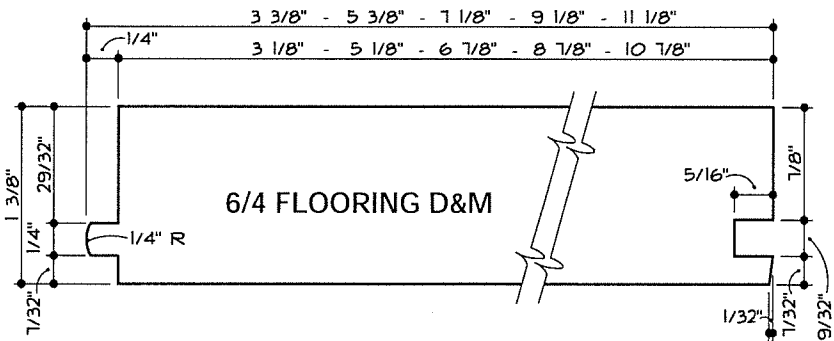
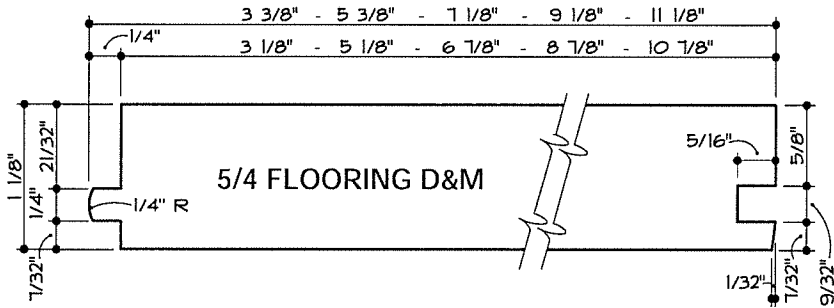
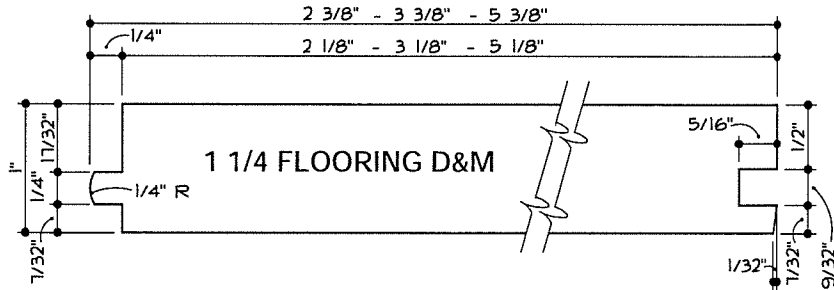
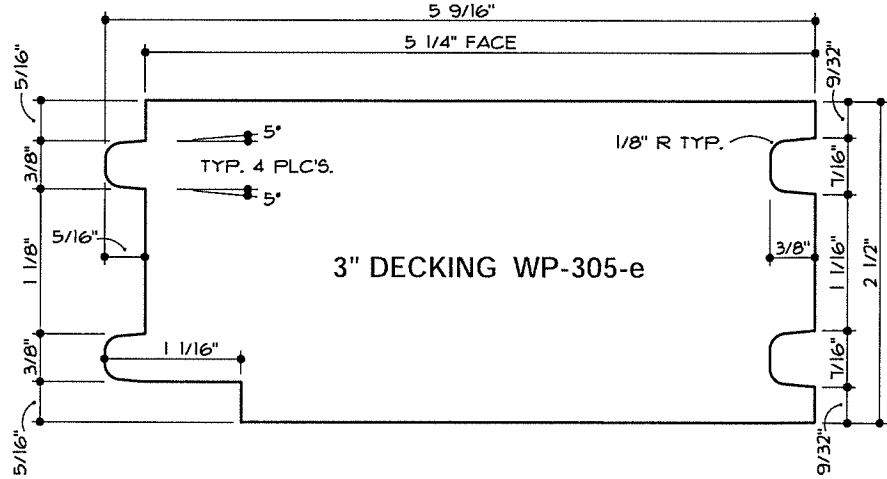

Flooring

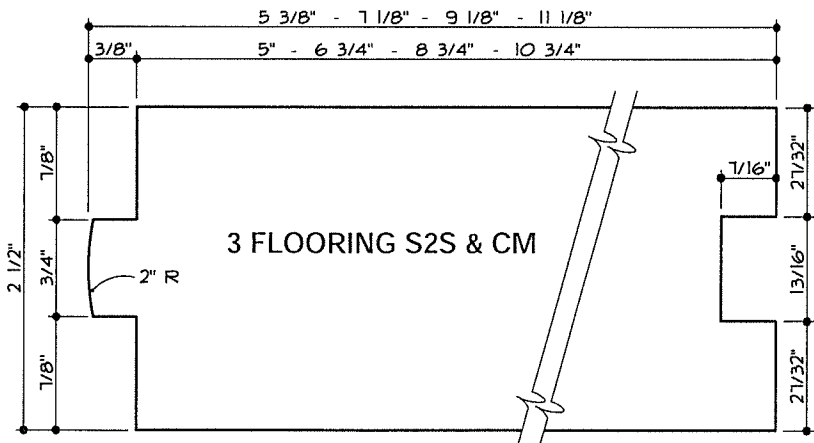
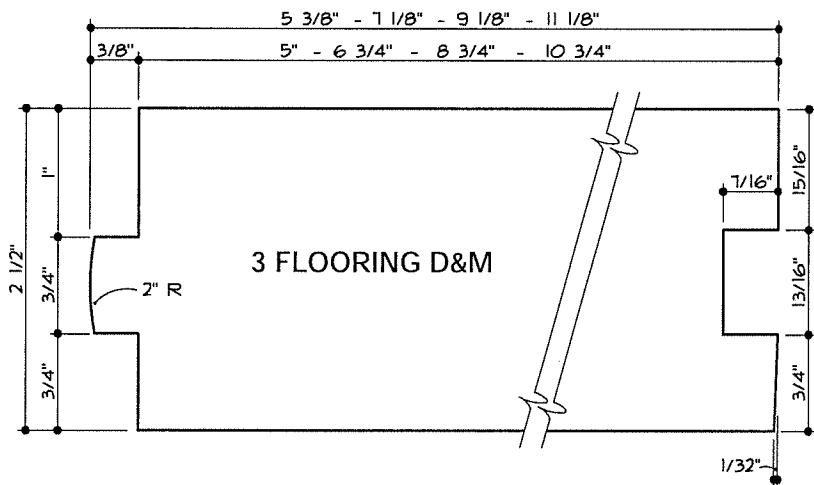
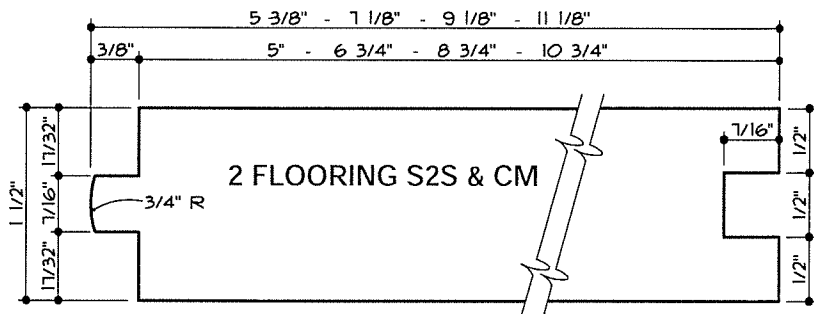
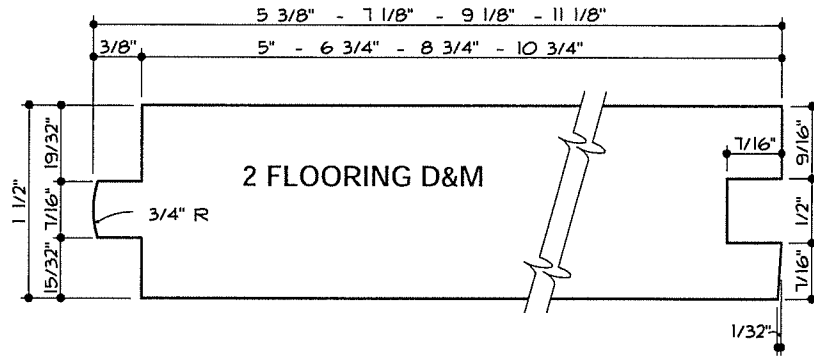

Corn Cribbing

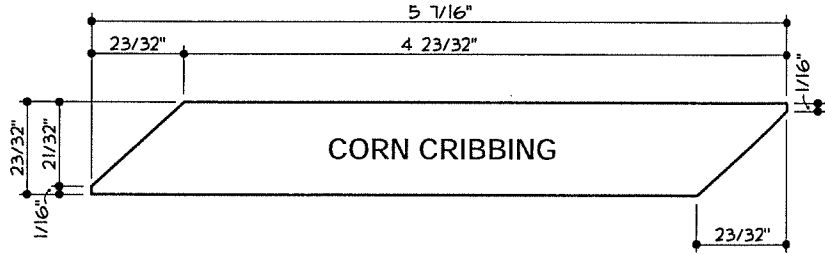

Grooved Roofing

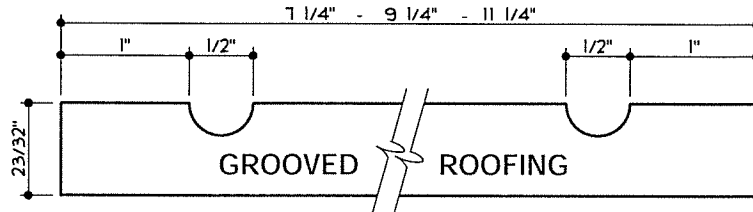

Patent Lath

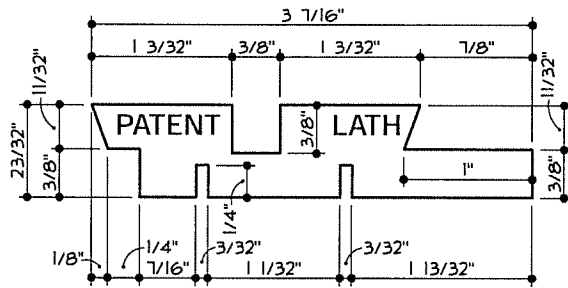

Stile

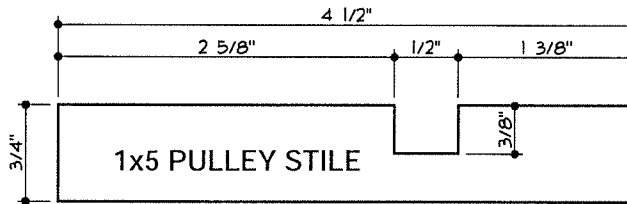

Sill

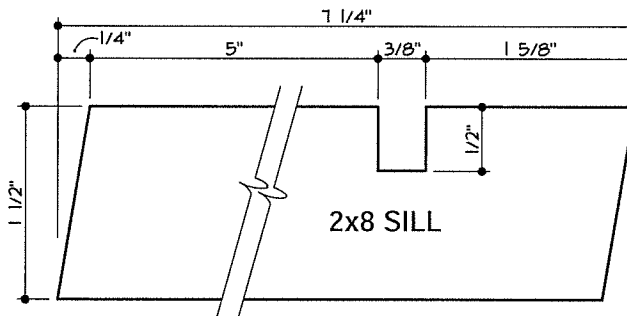

Jamb

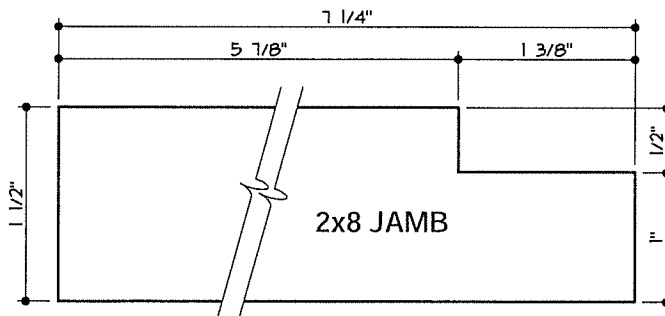

Ogee Batten

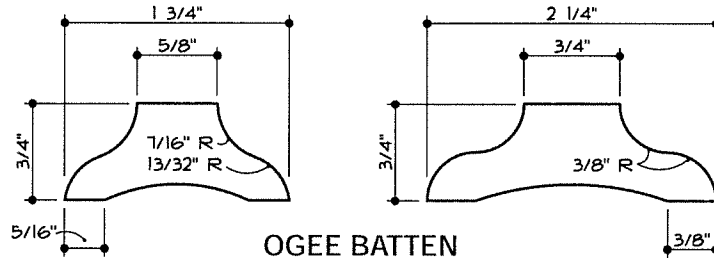

Casket Stock

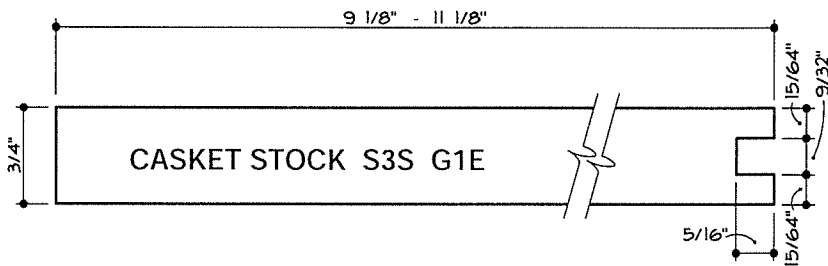
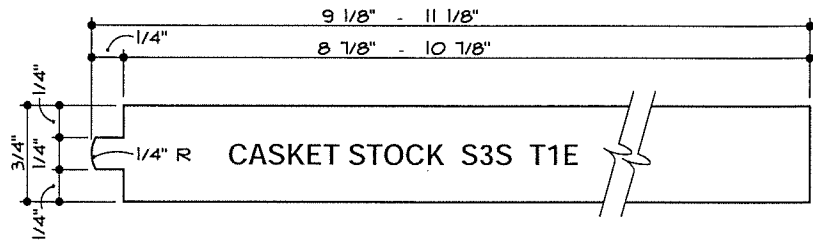

Beaded Shelving

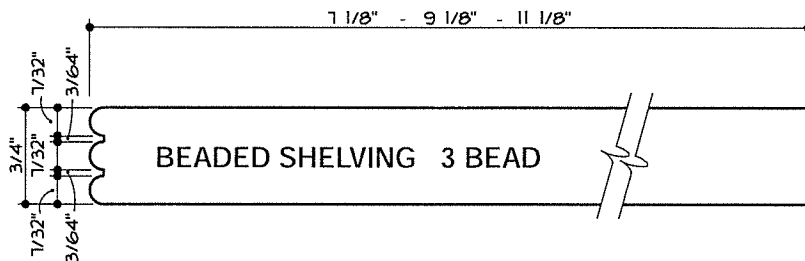
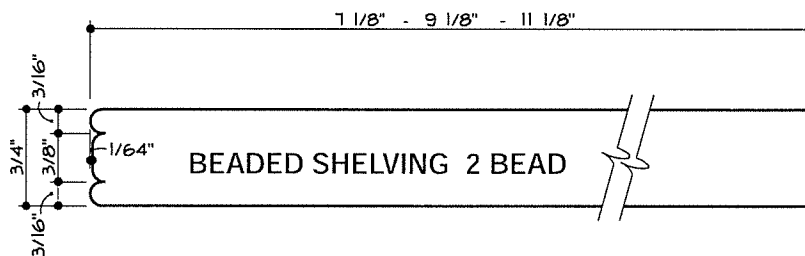

Coverage Calculations

Siding and paneling are usually sold either by the lineal (*running*) foot or by the board foot.

To simplify cost and coverage estimations, select the appropriate factor from the table at right according to how the material is priced. The factors provided in the table can be used to calculate the amount of siding required either in lineal feet or in board feet.

In either case, the square footage of the area to be covered is calculated first, then multiplied by the appropriate factor.

Procedure:

- A) Calculate the square footage in walls:
length x width = sq. ft.
- B) Calculate, and then subtract, the square footage of openings. Now add 10% for trim and waste.
- C) Multiply the result by either the factor for lineal feet or the factor for board feet.
- D) Multiply the total footage required by price.

Additional Information

Additional information and titles referenced in this publication are available for purchase from WWPA.

For a full description of technical publications available and a printable order form, go to the WWPA Internet site at www.wwpa.org.

You also can receive an order form via fax through the WWPA Fax Delivery Service by calling 732-544-2876 and following the instructions.

COVERAGE ESTIMATOR

Pattern	Nominal Width	Width		Factor for Lineal Feet ¹	Factor for Board Feet ²
		Dressed	Exposed Face		
Bevel & Bungalow	4	3½	2½	4.8	1.60
	6	5½	4½	2.67	1.33
	8	7¼	6¼	1.92	1.28
	10	9¼	8¼	1.45	1.21
Dolly Varden	4	3½	3	4.0	1.33
	6	5½	5	2.4	1.2
	8	7¼	6¾	1.78	1.19
	10	9¼	8¾	1.37	1.14
Drop, T&G and Channel Rustic	12	11¼	10¾	1.12	1.12
	4	3¾	3½	3.84	1.28
	6	5¾	5½	2.34	1.17
	8	7½	6¾	1.75	1.16
Log Cabin	10	9½	8¾	1.35	1.13
	6	5⅞	4⅞	2.43	2.43
	8	7⅞	6⅞	1.81	2.42
Boards	10	9⅞	8⅞	1.39	2.32
	2	1½			
	4	3½			
	6	5½			
	8	7¼			

¹ Lineal Foot Factor is derived by dividing 12" by the exposed face width.

² Board Foot Factor is derived by dividing the nominal width by the exposed face width and is based on nominal 1" stock, except log cabin. Log cabin is based on 2" thickness. For nominal 1½" log cabin, multiply by .75.

Note: Factors do not include any allowance for trim or waste and do not apply to diagonal installations. A 10% allowance (for trim and waste) should be added to the square footage required before the factors are used. Refer to *Procedure* at left.

Checklist for a Siding Material Specification

- Select species suited to the project.
- List grade names, paragraph numbers and rules-writing agency. (Refer to Grade Selector chart on back cover).
- Specify surface texture for exposed face.
- Specify moisture content suited to the project.
- If gradestamped, specify lumber to be stamped on back or ends. (WWPA's *Specifying Lumber* [A-2] offers additional information.)
- Specify VG (vertical grain) if appropriate and available.
- Specify pattern and size (WWPA's *Natural Wood Siding* [TG-8] and *Paneling Basics* [A-3] offer additional information.)

Western Lumber Grades

GRADE SELECTOR CHART-ALL SPECIES							
General Categories <i>(Note that there are additional grades for bevel pattern.)</i>		GRADES			Grade Rule Paragraph Numbers for Reference & Specifying		
		WESTERN SPECIES		CEDAR Western & Canadian	WWPA ²	WCLIB ³	NLGA ⁴
		Selects ¹	Finish				
All Patterns	Premium Grades	B&Better (IWP Supreme)	Superior Prime	Clear Heart⁵	20.11	102-b	200a
		C Select⁵ (IWP Choice)		A Grade⁵	10.11	-	-
		D Select⁵ (IWP Quality)		B Grade	20.12	102-c	200b
Additional Grades for Bevel Patterns	Premium		Superior Bevel	Clear VG Heart⁵	21.11	106-aa	201a
				A Bevel⁵	21.12	106-a	201b
	Knotty		Prime Bevel	B Bevel	16.11	-	-
				Rustic	21.13	106-b	201c
All Patterns	Knotty Grades	Commons ¹	Alternate Boards	Cedar	-	-	201d
					C Bevel	21.14	106-c
All Patterns	Knotty Grades	1 Common (IWP Colonial)	Select Merch. Construction	Select Knotty⁶ Quality Knotty⁶	16.12	-	-
		2 Common (IWP Sterling)			-	-	205a
		3 Common (IWP Standard)			-	-	205b
		4 Common (IWP Utility)			30.11	-	-
		5 Common (IWP Economy)			30.12	118-a	114a
			Standard Utility Economy		118-b	118-b	114b
					-	111-e	204a
					-	111-f	204b
					30.13	-	-
					118-c	118-c	114c
					30.14	118-d	114d
					30.15	118-e	114e

1 Equivalent grades, under the same paragraph numbers in WWPA Rules, are available in Idaho White Pine. Refer to *Western Lumber Grading Rules*.
2 Western Wood Products Association's *Western Lumber Grading Rules*.
3 West Coast Lumber Inspection Bureau's *West Coast Lumber Standard Grading Rules*.
4 National Lumber Grades Authority's *Standard Grading Rules for Canadian Lumber*.
5 Some clear grades may be specified VG (vertical grain). Common practice is to ship orders as a combination of vertical and flat grain, unless specified otherwise.
6 The widely used marketing term, "STK" usually describes a combination of Select Knotty and Quality Knotty, sometimes marketed with approximately 15% of the order in Quality Knotty.
The grade names in bold face type are the most widely available grades. These are often specified as a grade combination that includes some portion of material in the next higher grade; i.e. C&Btr Select, D&Btr Select, A&Btr Cedar, 2&Btr Common, 3&Btr Common or Std&Btr (Standard & Better).



WESTERN WOOD PRODUCTS ASSOCIATION

522 SW Fifth Avenue, Suite 500
 Portland, OR 97204-2122
 tel: 503-224-3930 e-mail: info@wwpa.org
 fax: 503-224-3934 web site: www.wwpa.org

